

# ABB central inverters CORE-500.0/1000.0-TL 500 to 1000 kW



Specifically tailored for the fast growing Chinese market, the CORE-500.0 and 1000.0 incorporate a number of key features including a maximum input voltage of up to 1000 Vdc, enabling high design flexibility and reduced DC distribution losses for large-scale PV applications.

With a best in class MPPT voltage range: 500...950 V@320 Vac and 2 independent MPPT (CORE-1000.0-TL) this new line of central inverters enables maximum flexibility in the configuration of the PV plant, ensuring a fast return on the investment.

The CORE-500.0 and 1000.0-TL inverters, aimed at system integrators and end users who require high performance solar inverters for large

photovoltaic power plants, offer the combination of maximum performance with an affordable capital expenditure.

#### Easy to use and install

Delivered fully equipped for connection to the grid, the CORE inverters are designed for a fast and easy installation with no additional accessories required. Moreover, the user-friendly interface and modular design enable ease of operation and maintenance.

#### Reverse polarity detection minimizes potential damage caused by incorrect wiring of the array

The CORE product is a transformerless inverter for direct connection to the MV transformer leading to longer MTBF (mean time between failures).

#### Operates in any conditions

The CORE's compact chassis and indoor enclosure with its IP20 construction allow for optimal operation in extreme weather conditions and environments. CORE has a -25°C to 45°C ambient temperature range as well as a 3000 m maximum operating altitude.

#### Highlights

- High efficiency with electrolytic-free capacitor leading to longer MTBF (mean time between failures)
- Integrated DC and AC distribution and protection
- Fully equipped for connection to the grid without the need of additional accessories
- Two independent RS-485 communication interfaces for inverter and intelligent string combiner monitoring

# ABB central inverters

## Additional highlights

- Compact size and weight
- 7" LCD touchscreen display (optional)
- 1000 Voc (open circuit voltage) rating
- IP20 construction for indoor applications allows operation in any weather conditions and environments
- Complies with Chinese grid standards GB/T-19964-2013 and GB/T-29319-2012
- Complete grid support: LVRT, ZVRT capability
- 12 pairs of DC inputs for CORE-1000.0-TL, 6 for CORE-500.0-TL for maximum flexibility in fuse rating

## Solar inverters from ABB

ABB central inverters are the result of more than 40 years of industry experience and proven technology. ABB central inverters are ideal for large PV power plants as well as PV systems

installed on commercial or industrial buildings. ABB central inverters provide a rapid return on investment with their compact and modular design, high efficiency and proven components.



## Technical data and types

Type code	CORE-500.0-TL	CORE-1000.0-TL
<b>Input side</b>		
Absolute maximum DC input voltage ( $V_{max,abs}$ )	1000 V	
MPPT input DC voltage range ( $V_{MPPTmin} \dots V_{MPPTmax}$ ) at $V_{acr}$	500...950 V@320 Vac Linear derating from MAX to 36%Pout [850< $V_{MPPT}$ <950 V] <sup>5)</sup>	
MPPT input DC range ( $V_{MPPTmin} \dots V_{MPPTmax}$ ) at $P_{acr}$ and $V_{acr}$	500...850 V @ 320 V <sup>5)</sup>	
Number of independent MPPT multi-master	1	2
Possibility of input poles configuration	Floating / negative or positive grounding <sup>3)</sup>	Floating
Maximum combined DC input current ( $I_{dc,maxc}$ )	1150 A	2300 A (2 x 1150A)
Maximum DC input current for each module ( $I_{dc,max,m}$ )	1150 A	
Number of DC inputs pairs	6	12
DC connection type	6 x 300 mm <sup>2</sup> (maximum lug width 30 mm ) M10	12 x 300 mm <sup>2</sup> (maximum lug width 30 mm ) M10
<b>Input protection</b>		
Reverse polarity detection	YES, in accordance with NBT32004-2013	
Input over voltage protection - SPD	1 for each input (Class II)	
Photovoltaic array isolation control	YES, in accordance with NBT32004-2013	
Fuse size each input poles	250...400 A	
DC switch each input module	1250 A	
Ground fault fuse size	5 A...1000 V <sup>4)</sup>	
<b>Output side</b>		
AC grid connection type	Three-phase 3W+PE	
Rated AC power ( $P_{acr}$ @ $\cos\phi=1$ )	500 kW	1000 kW
Maximum AC output power ( $P_{ac,max}$ @ $\cos\phi=1$ )	550 kW@30°C	1100 kW@30°C
Maximum apparent power ( $S_{max}$ )	550 kVA@30°C	1100 kVA@30°C
Rated grid voltage ( $V_{acr}$ )	320 V	
AC voltage range ( $V_{ac,min} \dots V_{ac,max}$ )	272...368 V <sup>1)</sup>	
Maximum output current ( $I_{ac,max}$ )	992 A	1984 A
Rated frequency ( $f_r$ )	50 Hz	
Frequency range ( $f_{min} \dots f_{max}$ )	47...53 Hz <sup>2)</sup>	
Nominal power factor and adjustable range	> 0.995 (adj. $\pm$ 0.90)	
Total harmonic distortion	< 3%	
AC connection type (for each phase)	2 x 300 mm <sup>2</sup> (maximum lug width 30 mm ) M10	4 x 300 mm <sup>2</sup> (maximum lug width 30 mm ) M10
Standard installation type	IT	
<b>Output protection</b>		
Anti-islanding protection	According to local standard	
Output overvoltage protection - SPD	Yes (Class II)	
Night time disconnect	Yes	
AC switch	1250 A	2000 A
AC fuse for each module	1800 A	

## Block diagram of CORE-500.0/1000.0-TL

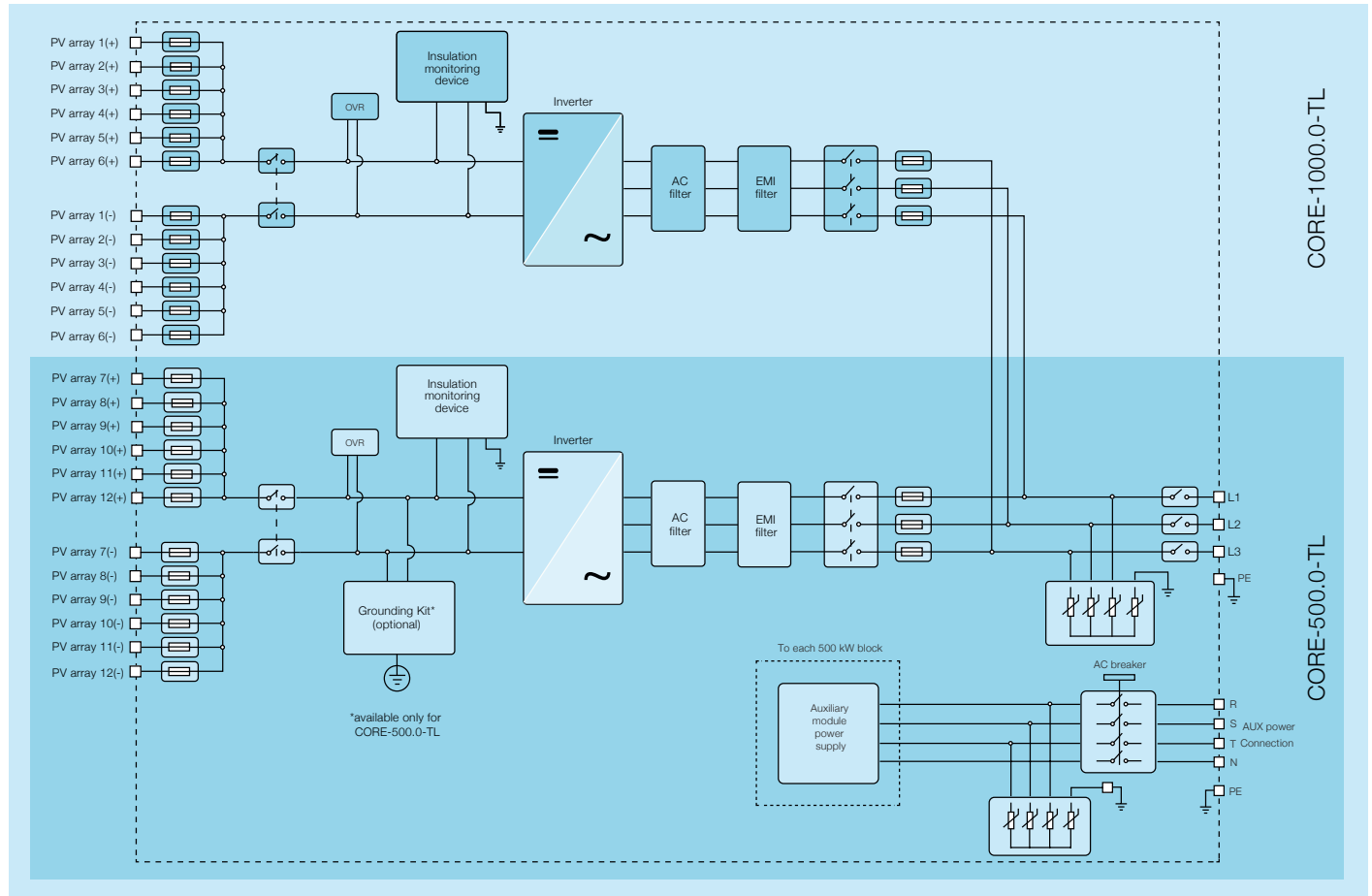

## Technical data and types

Type code	CORE-500.0-TL	CORE-1000.0-TL
<b>Auxiliary AC voltage</b>		
Auxiliary AC power supply connection	Three-phase 3W+N+PE	
Nominal auxiliary AC power supply voltage	400 Vac	
Nominal auxiliary AC power supply frequency	50 Hz	
Auxiliary power supply consumption	700 W	1400 W
Type of auxiliary AC connections	Screw terminal block - max cross-section 16 mm <sup>2</sup>	
Input over voltage protection - SPD	Yes (Class II)	
<b>Operating performance</b>		
Maximum efficiency ( $\eta_{max}$ )	98.7% <sup>6)</sup>	
Weighted efficiency ( $\eta_{EURO} / \eta_{CEC}$ )	98.4% / - <sup>6)</sup>	
Stand-by consumption	180 W	200 W
Inverter switching frequency	5 KHz	
<b>Communication</b>		
Wired local monitoring	PVI-USB-RS232_485 (opt.)	
Remote monitoring	VSN700 Data Logger (opt.)	
User interface	7" LCD touchscreen display (opt.)	
Communication port	RS485 (Aurora Protocol), RS485 (Modbus), Ethernet card (optional)	
<b>Environmental</b>		
Ambient temperature range	-25...+50°C / -13...122°F without derating <sup>5)</sup>	
Relative humidity	0...95% non condensing	
Noise emission (typical)	< 83 dB	
Maximum operating altitude without derating	3000 m / 9840 ft <sup>5)</sup>	
Environmental pollution classification for external environment	2	
Environmental category	Indoor	
<b>Physical</b>		
Environmental protection rating	IP 20	
Cooling	Air forced	
Required air cooling flow	2100 m <sup>3</sup> /h - 1236 cfm	4030 m <sup>3</sup> /h - 2372 cfm
Dimension (H x W x D)	1800 mm x 1600 mm x 800 mm / 70.8" x 63.0" x 31.5"	1800 mm x 2600 mm x 800 mm / 70.8" x 102.3" x 31.5"
Weight	1100 Kg / 2425 lb	2005 Kg / 4420 lb
<b>Safety</b>		
Safety class	I	
Transformer	Trasformerless	
Marking	CQC	
Safety and EMC standard	NB/T-32004-2013	
Grid standard	GB/T-19964-2013, GB/T-29319-2012	

<sup>1)</sup> The AC voltage range may vary depending on specific country grid standard

<sup>2)</sup> The frequency range may vary depending on specific country grid standard

<sup>3)</sup> The input configuration (floating; negative or positive pole grounded) must be specified on the special form upon placement of the order for the CORE inverter

<sup>4)</sup> The ground fault fuse is installed only if one of the input poles is connected to ground

<sup>5)</sup> Refer to the application curve on the Product Manual

<sup>6)</sup> Tests performed in accordance with IEC-61683

**Remark. Features not specifically listed in the present data sheet are not included in the product**

## Efficiency curves of CORE-500.0/1000.0-TL in accordance with IEC-61683

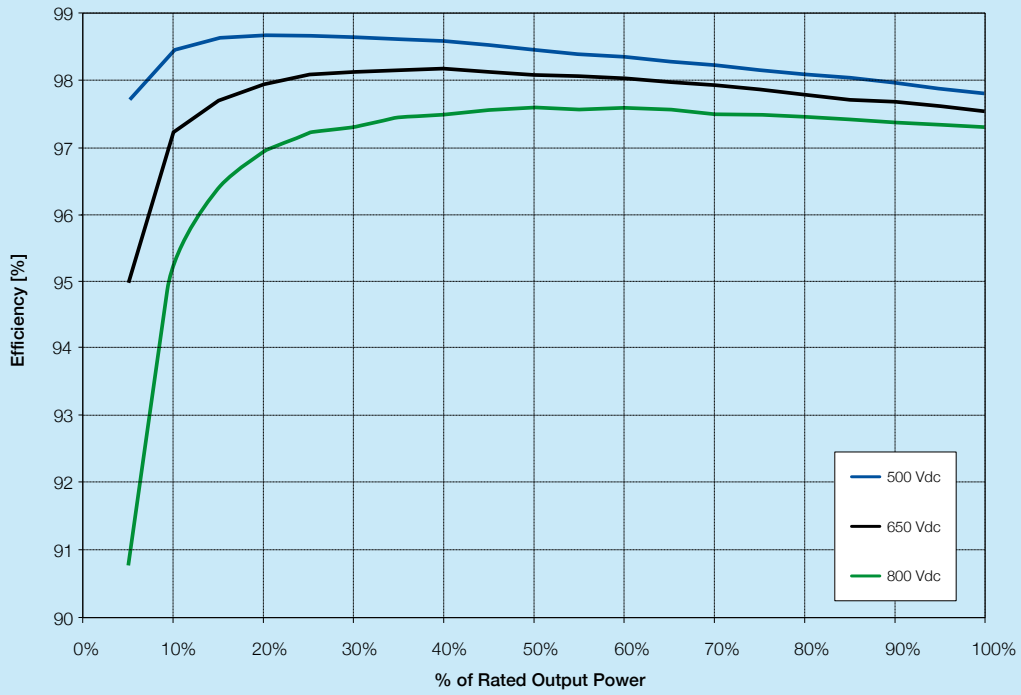

### Support and service

ABB supports its customers with dedicated, global service organization in more than 60 countries and strong regional and national technical partner networks providing complete range of life cycle services.

For more information please contact your local ABB representative or visit:

[www.abb.com/solarinverters](http://www.abb.com/solarinverters)

[www.abb.com/solar](http://www.abb.com/solar)

[www.abb.com](http://www.abb.com)

© Copyright 2015 ABB. All rights reserved.  
Specifications subject to change without notice.

